

20.02.1373.00

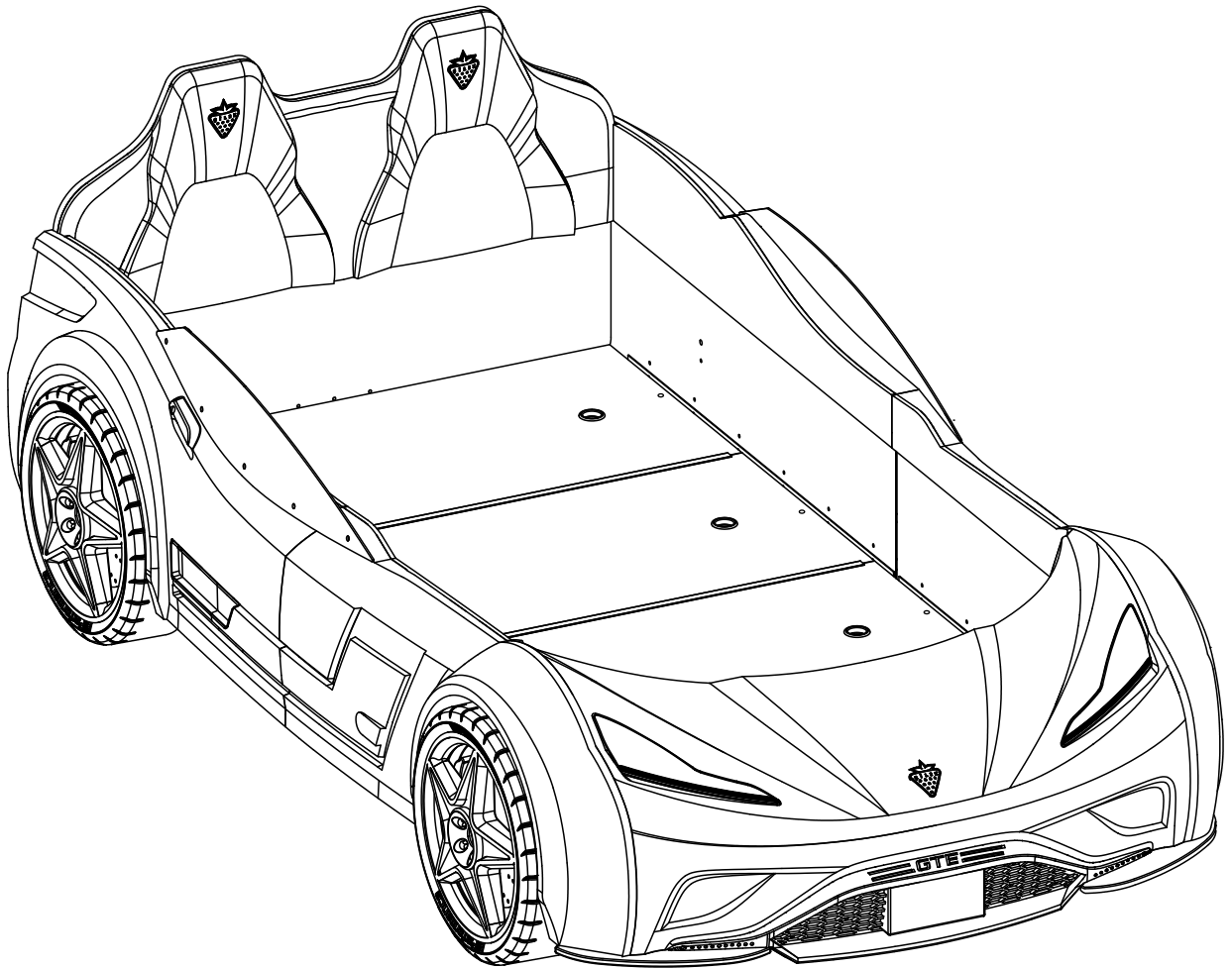

GARANTİ BELGESİ VE
KULLANMA KILAVUZU



WARRANTY CERTIFICATE
AND USER MANUAL

شهادة الضمان ودليل المستخدم



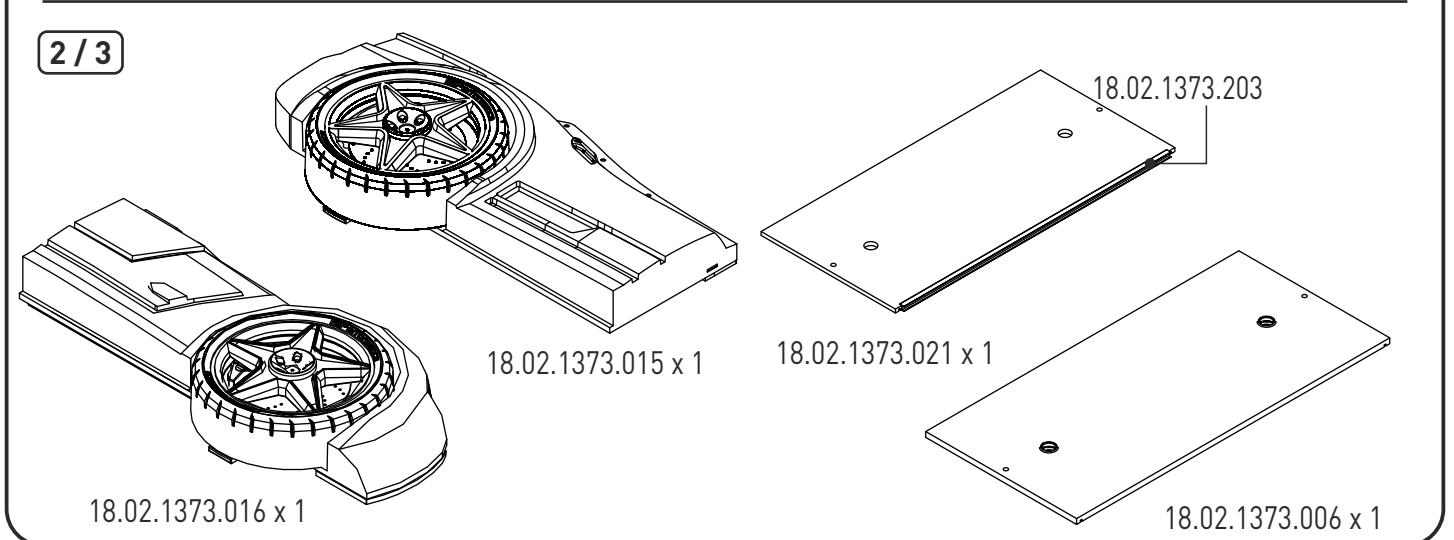
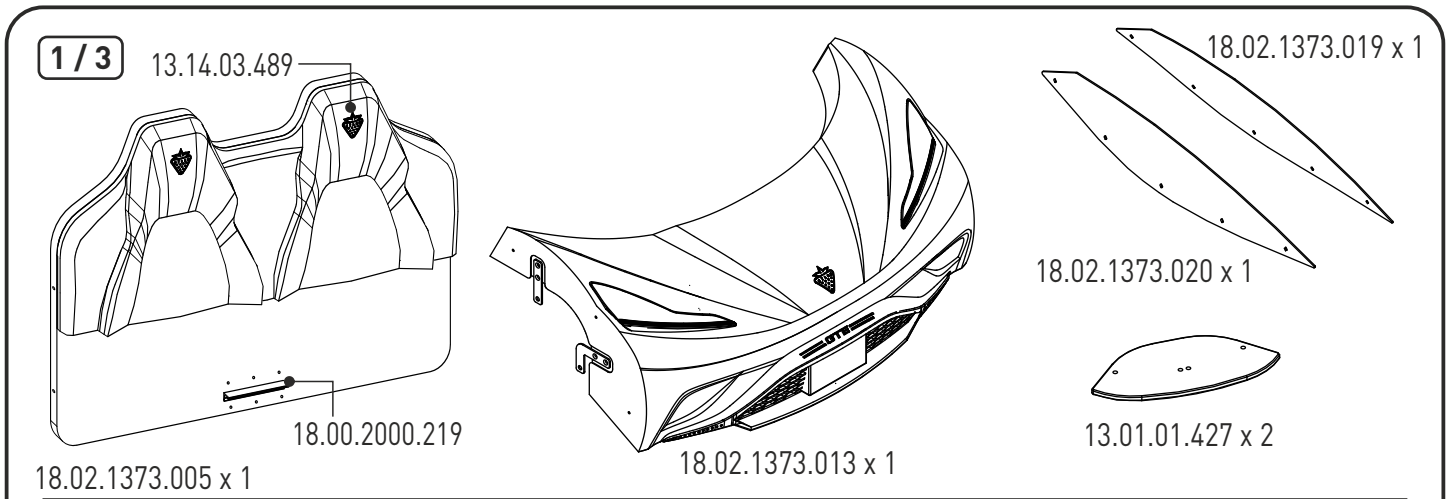
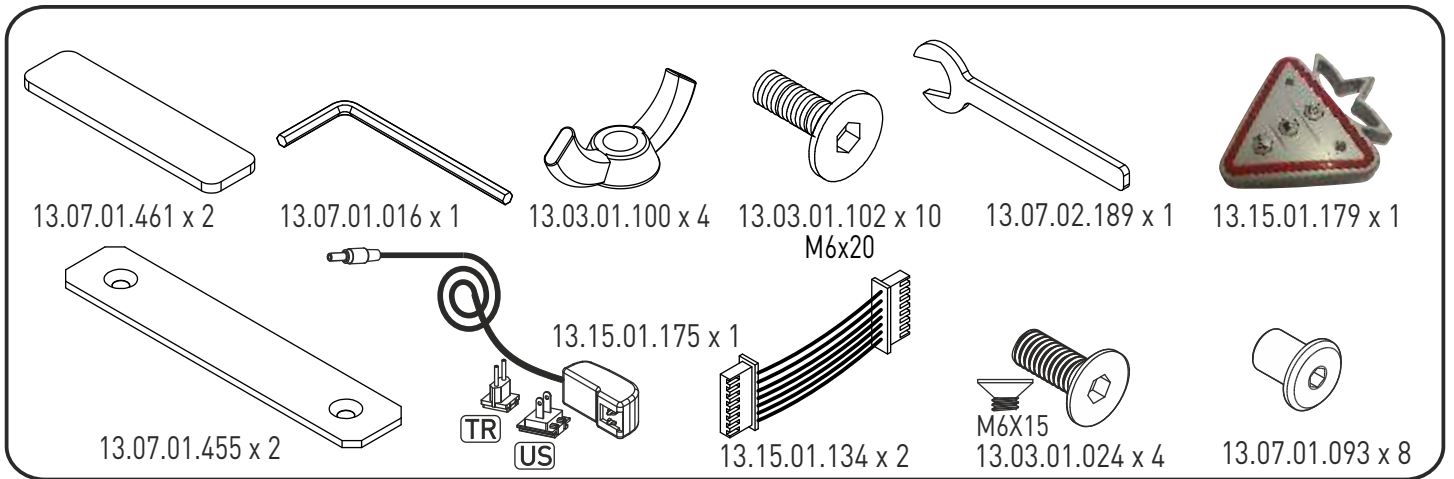
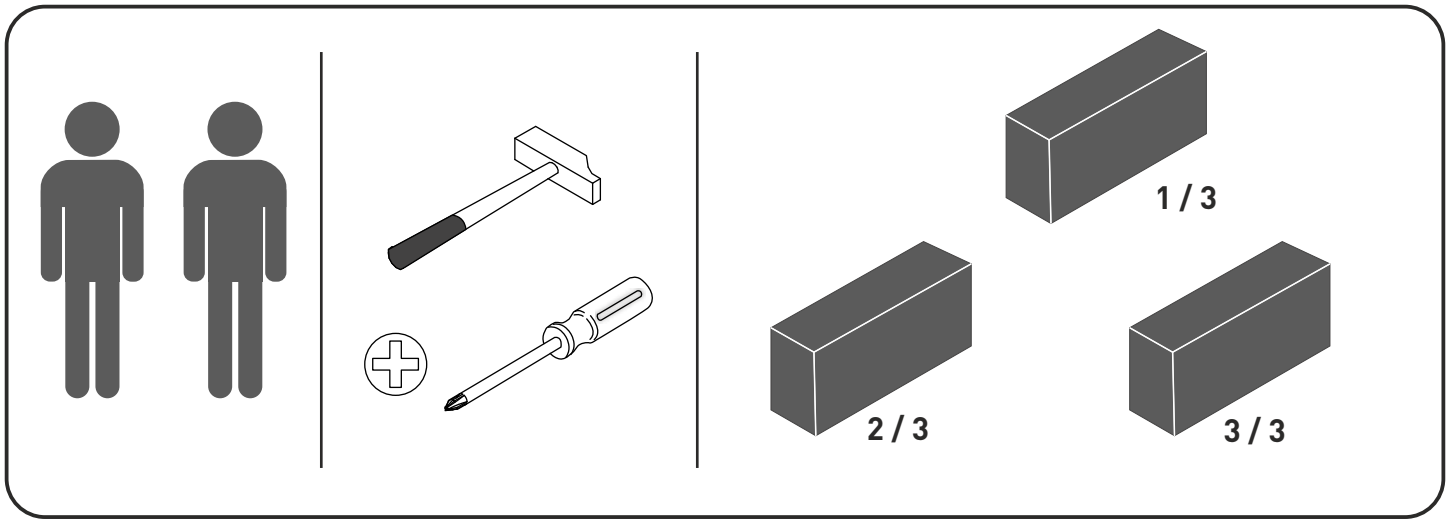

3 / 3

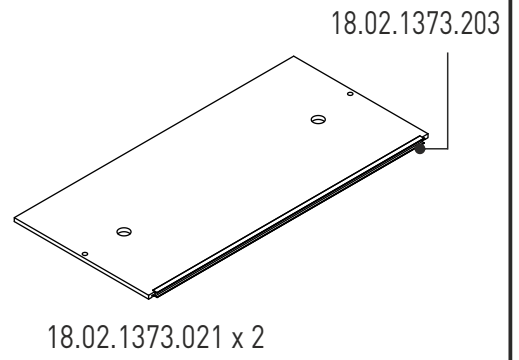
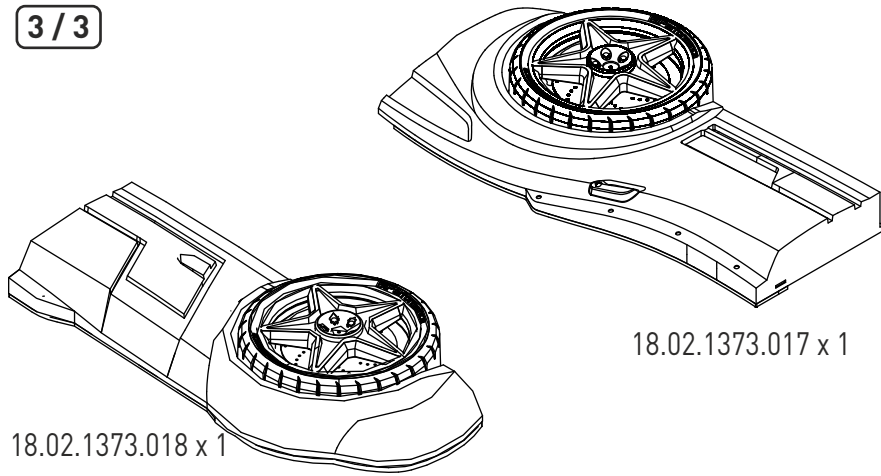

1

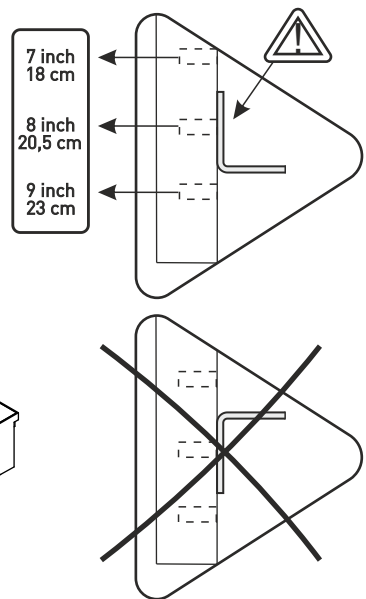
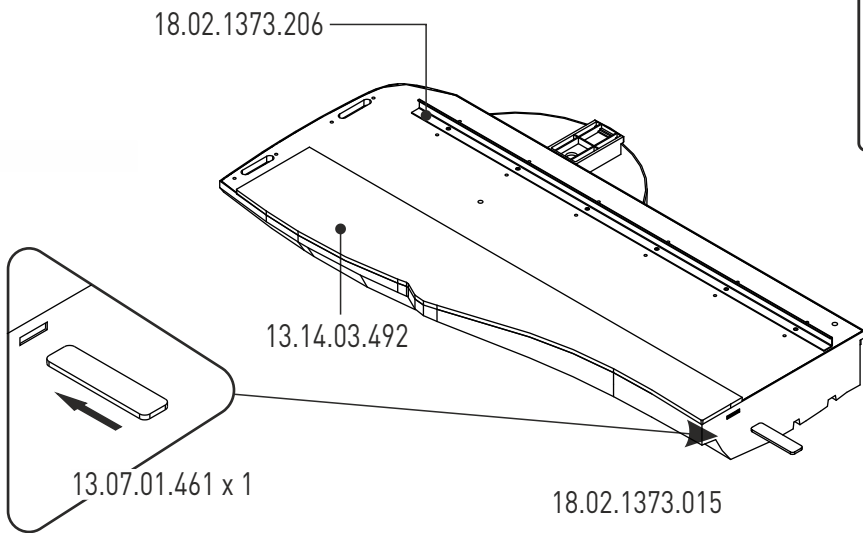

2

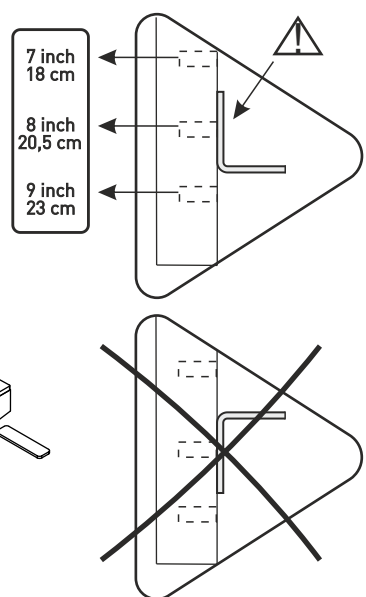
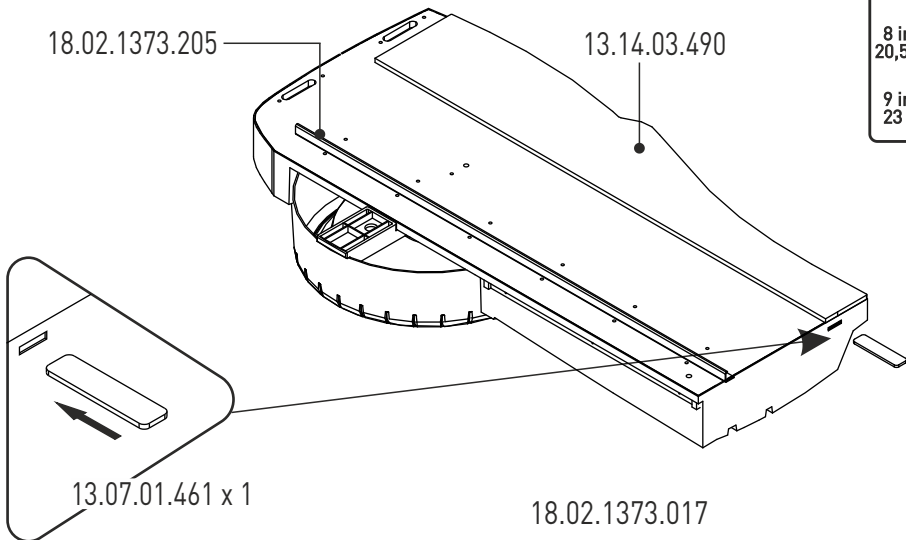

3

18.02.1373.207

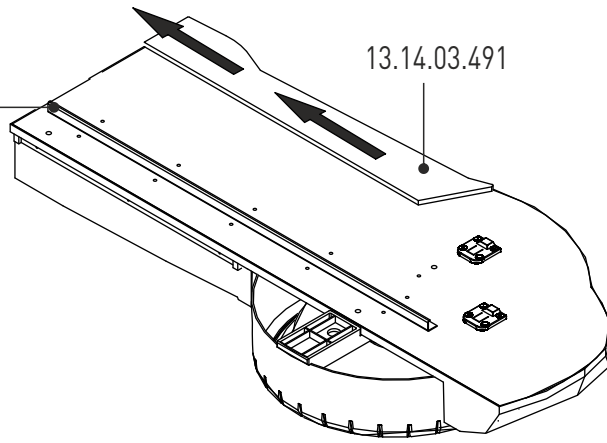

13.14.03.491

18.02.1373.018

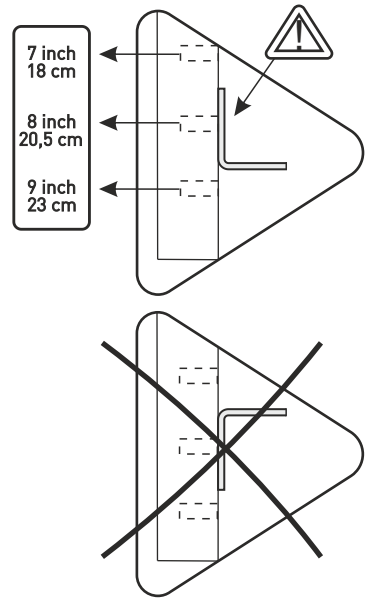

4

18.02.1373.208

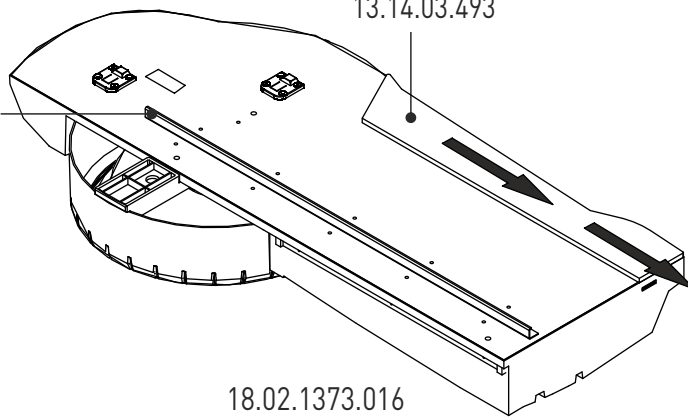

13.14.03.493

18.02.1373.016

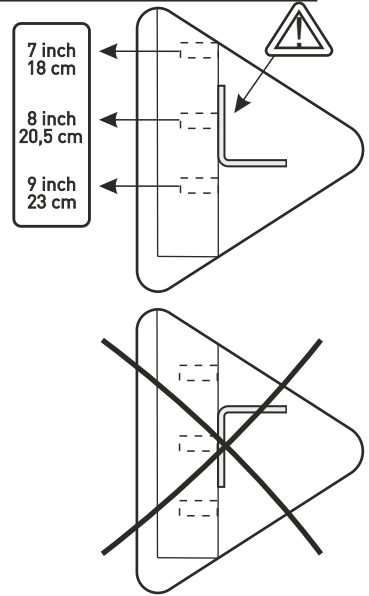

5

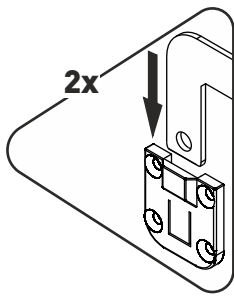
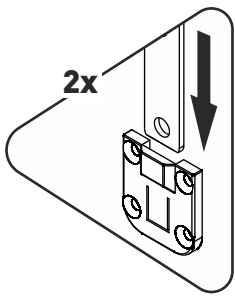

18.02.1373.016

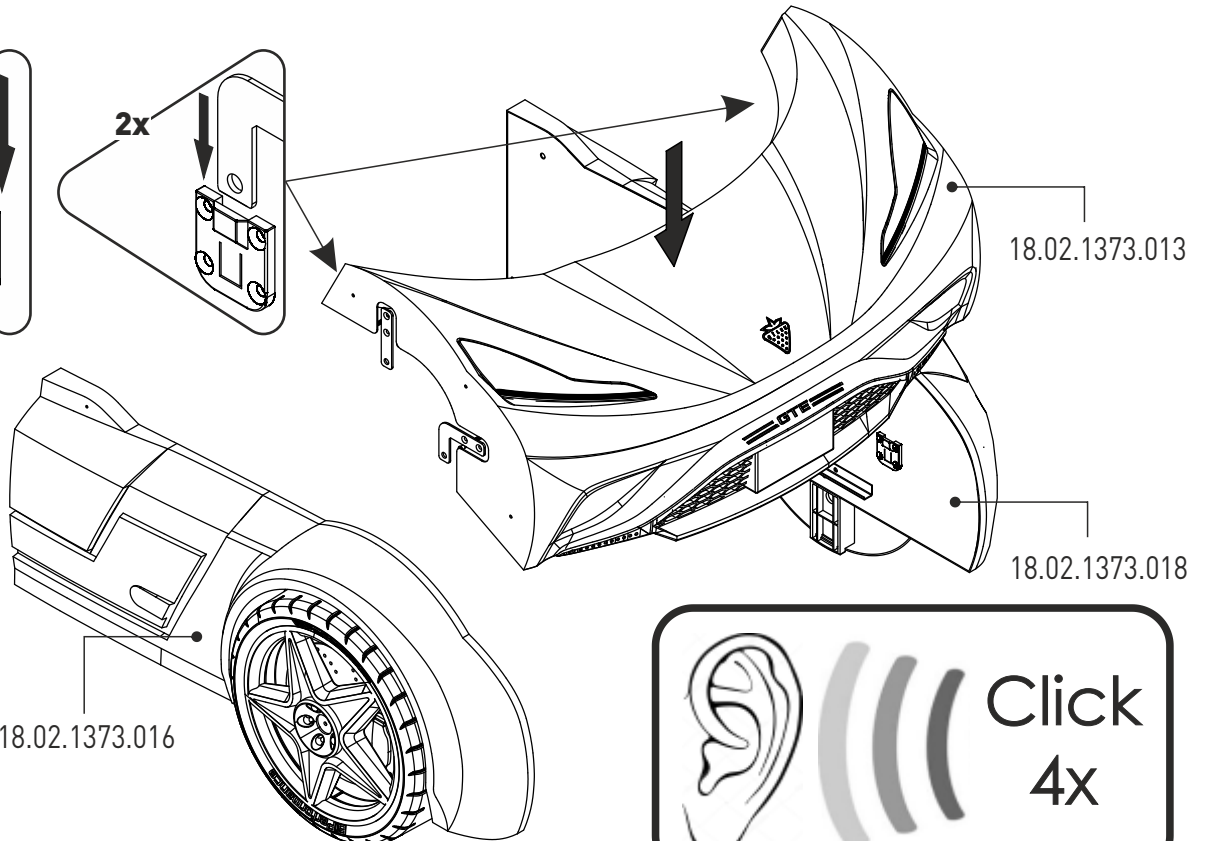

18.02.1373.013

18.02.1373.018



6

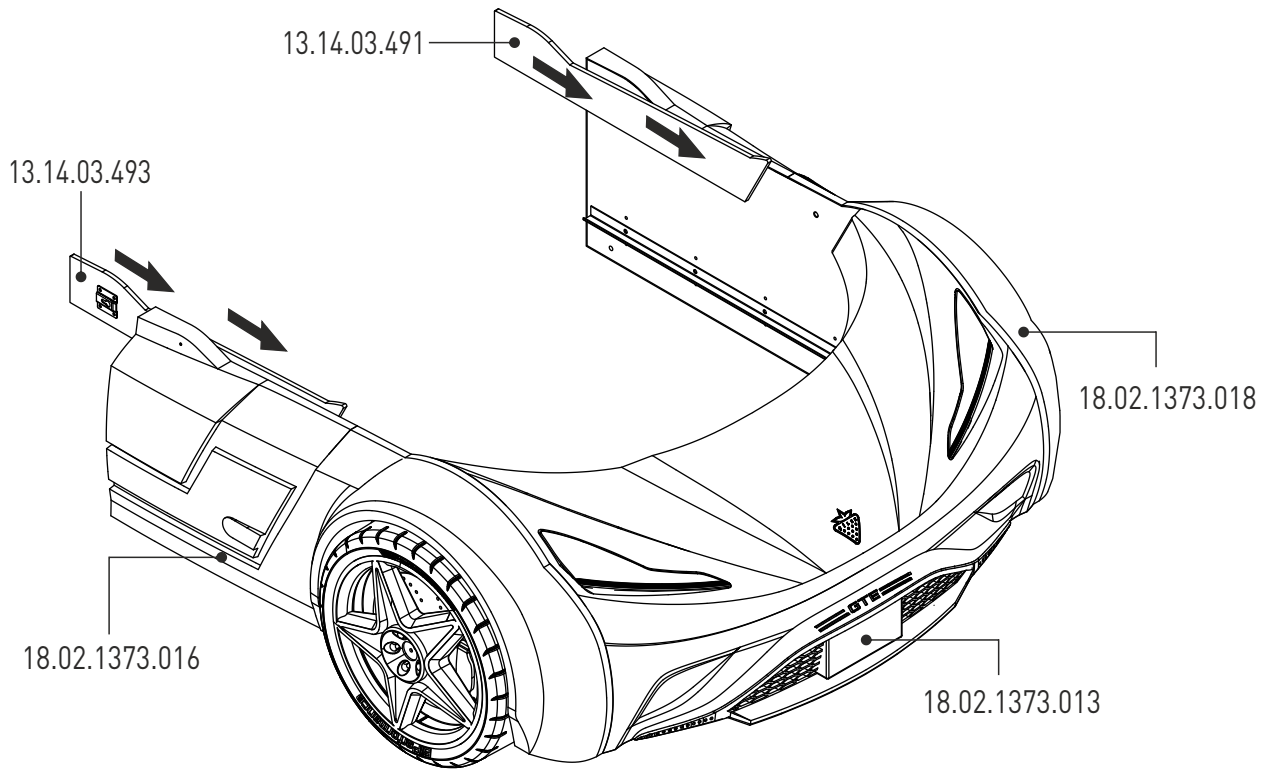

7

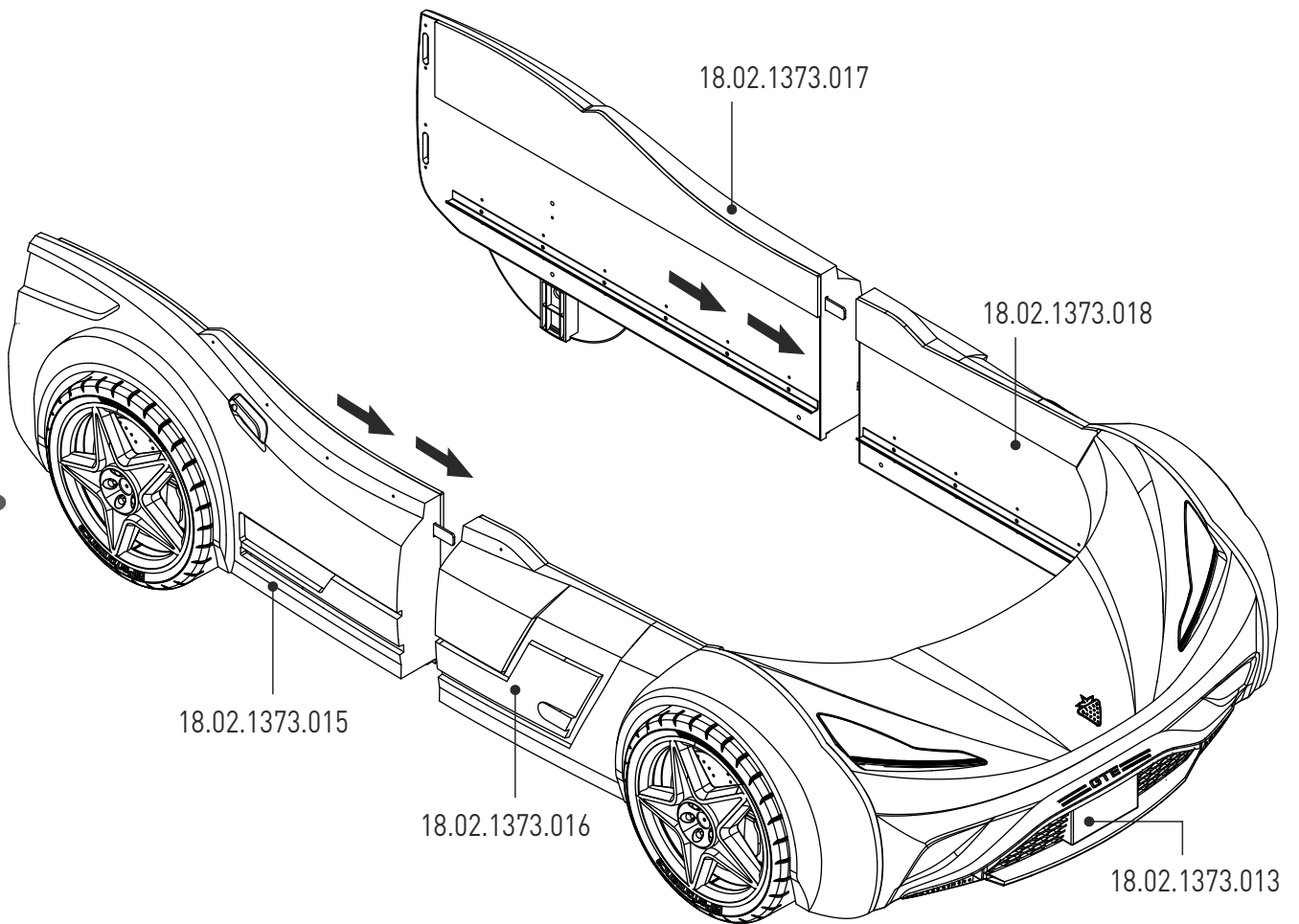

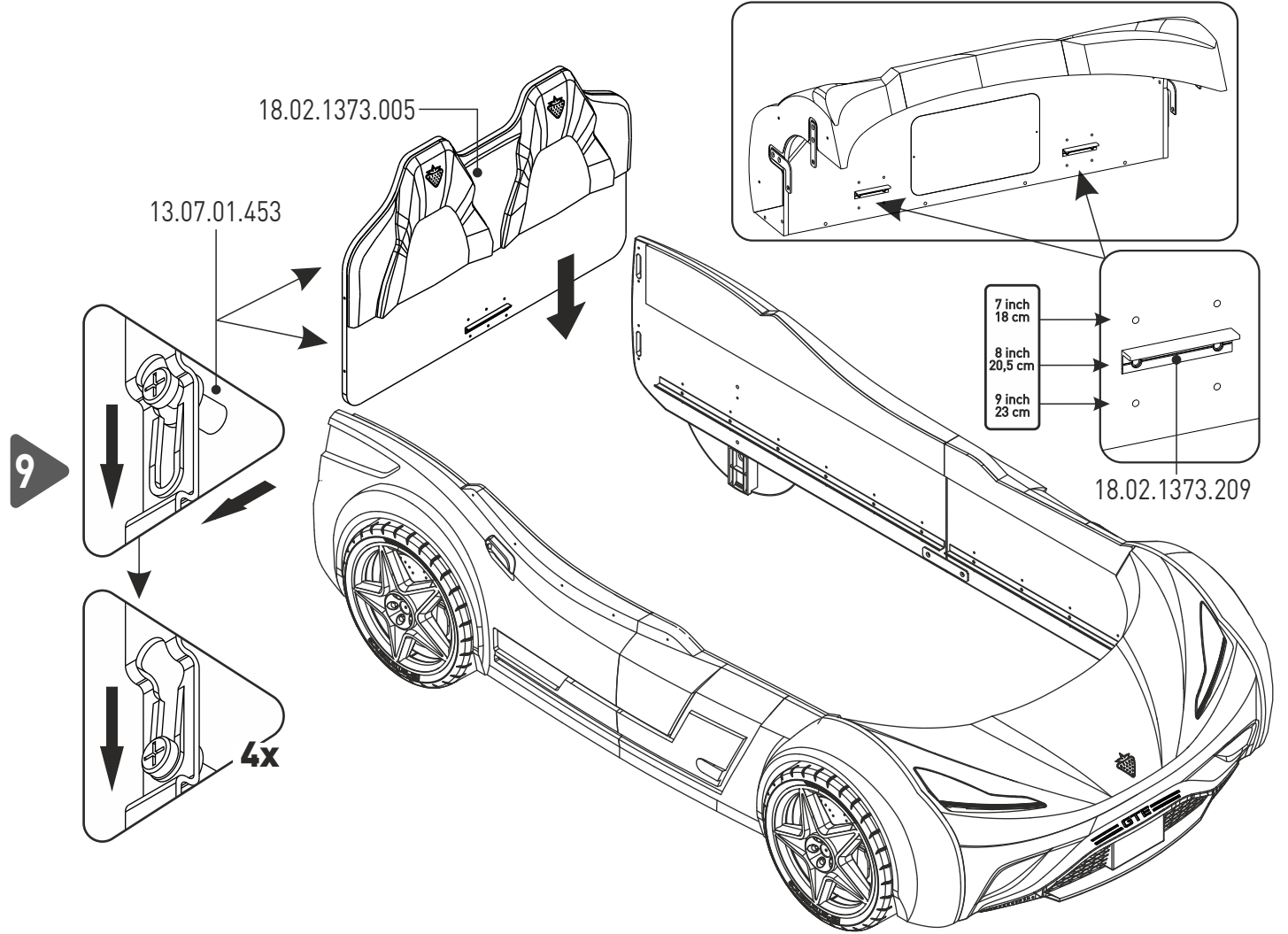
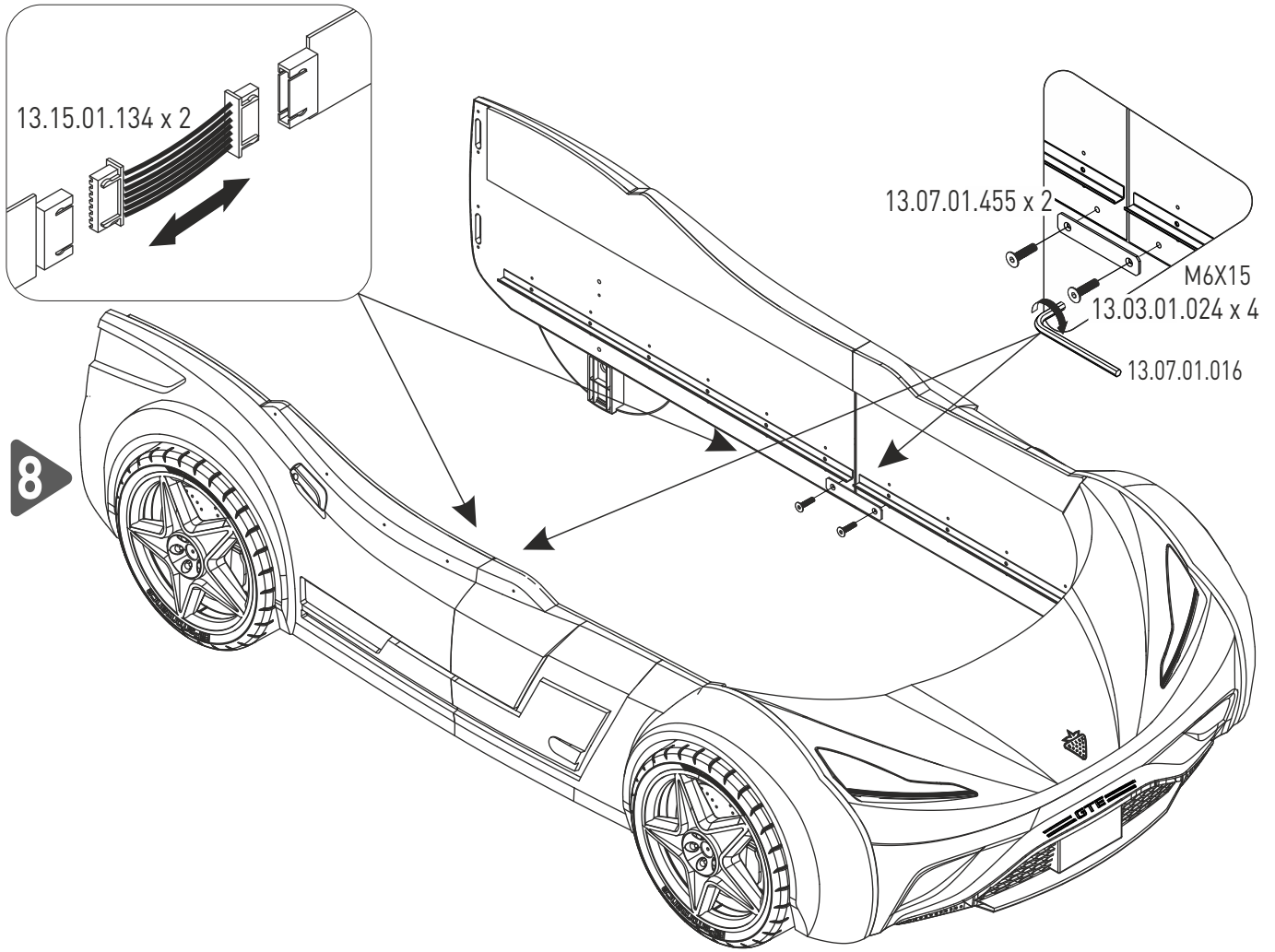

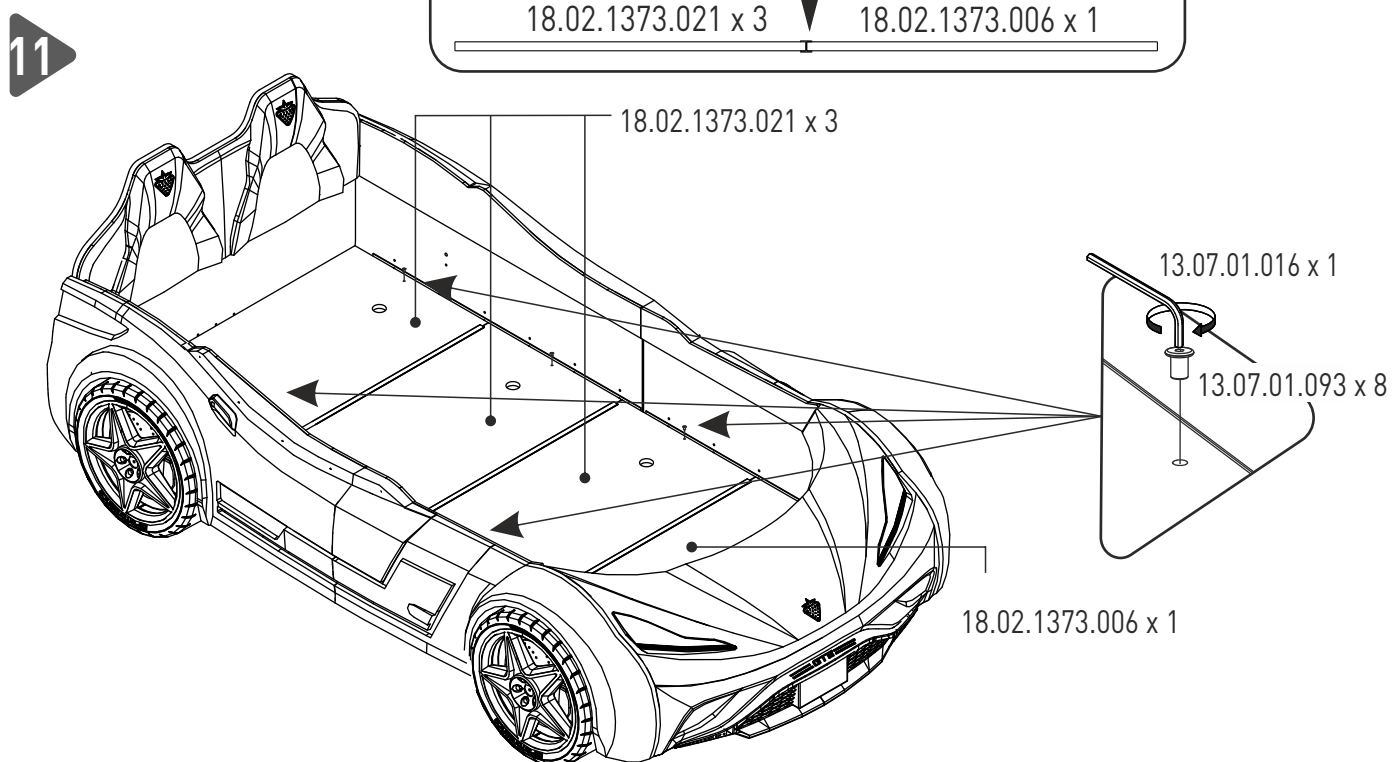
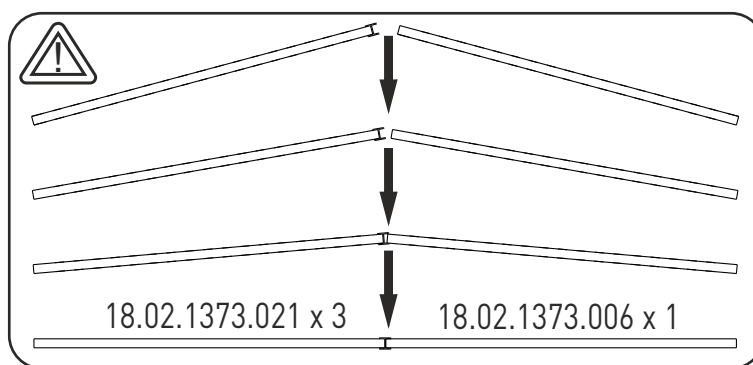
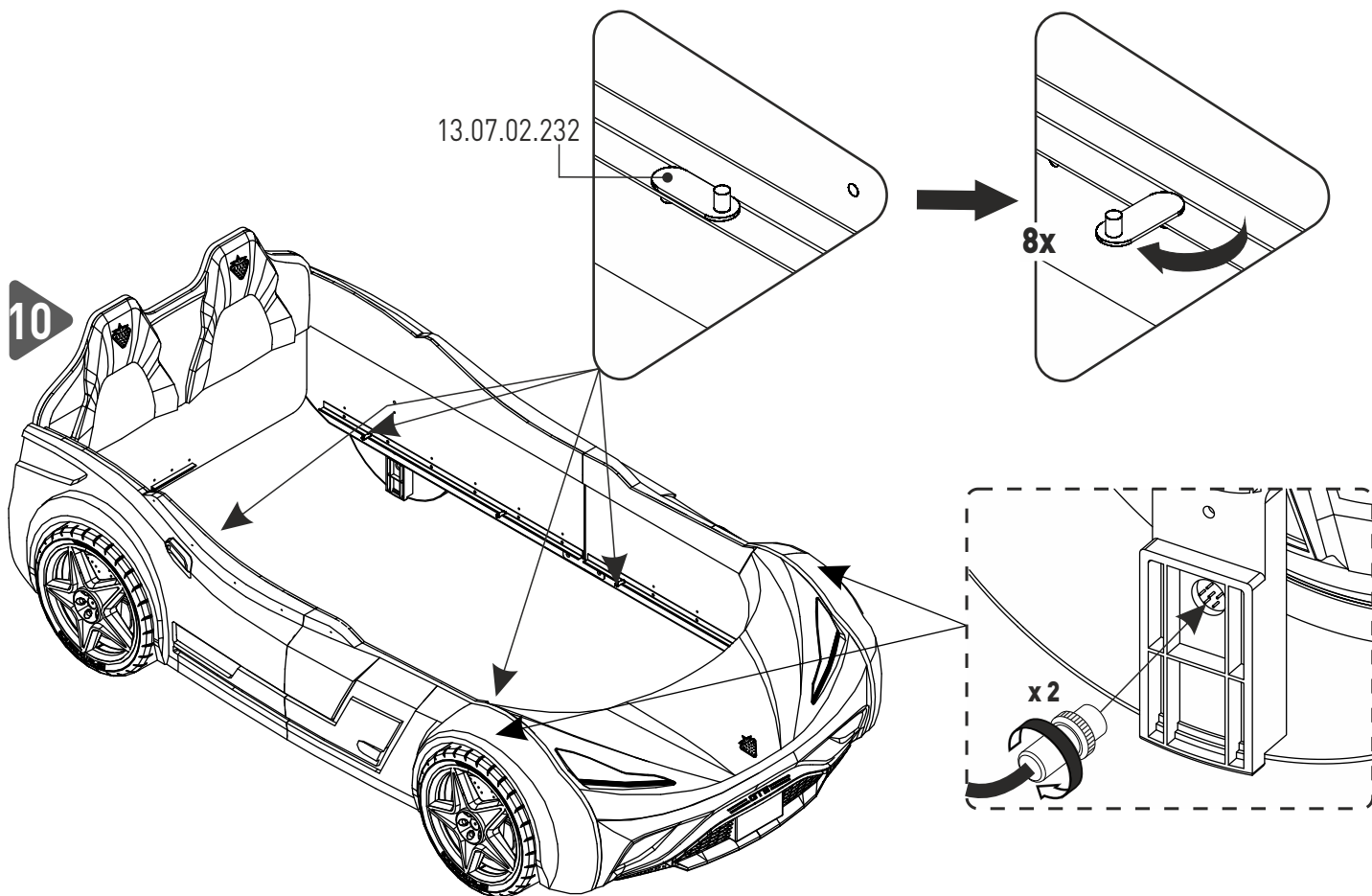

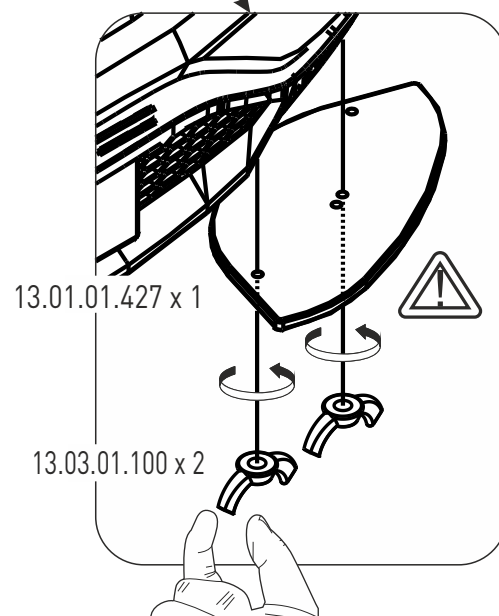
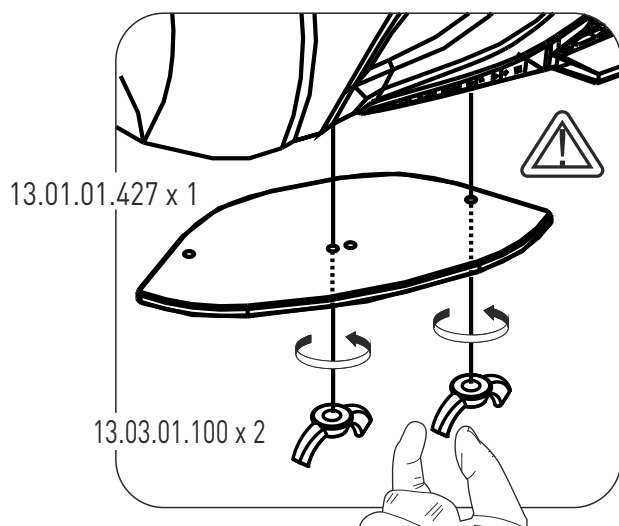
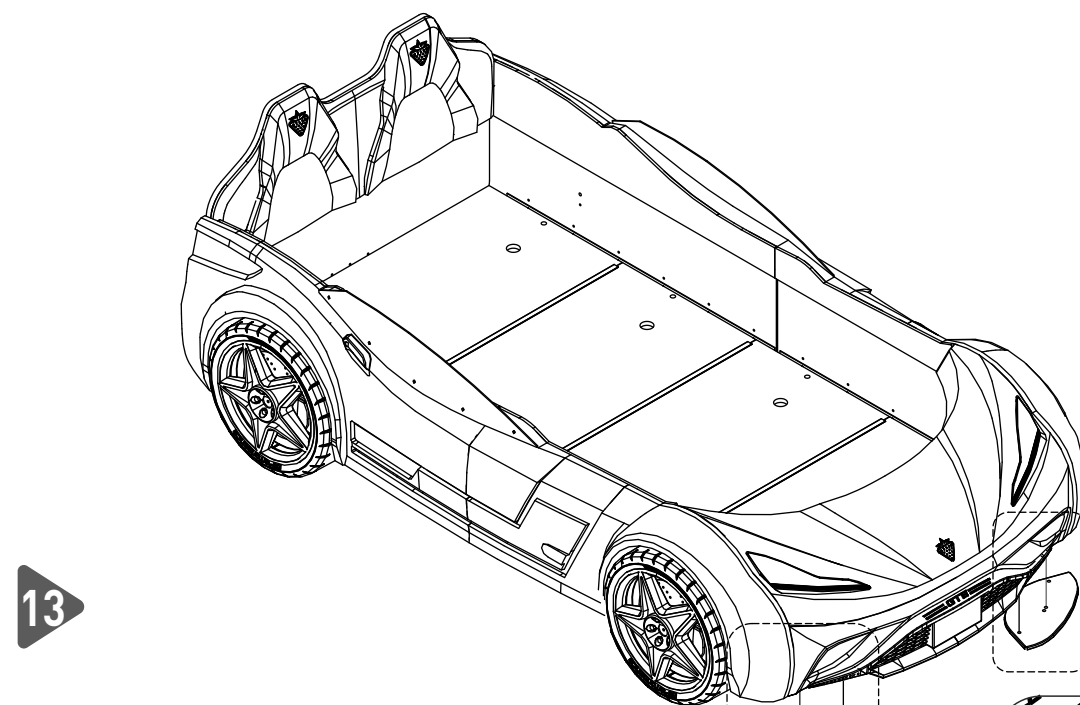
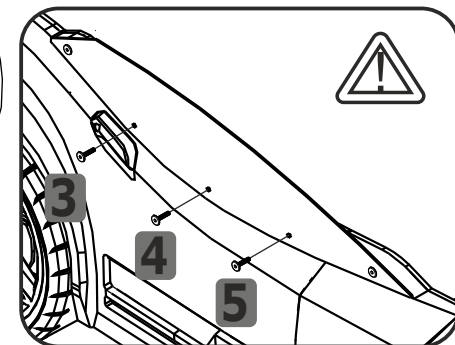
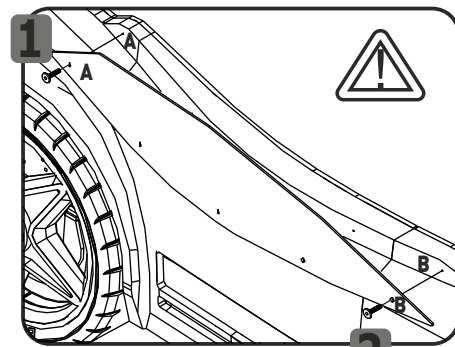
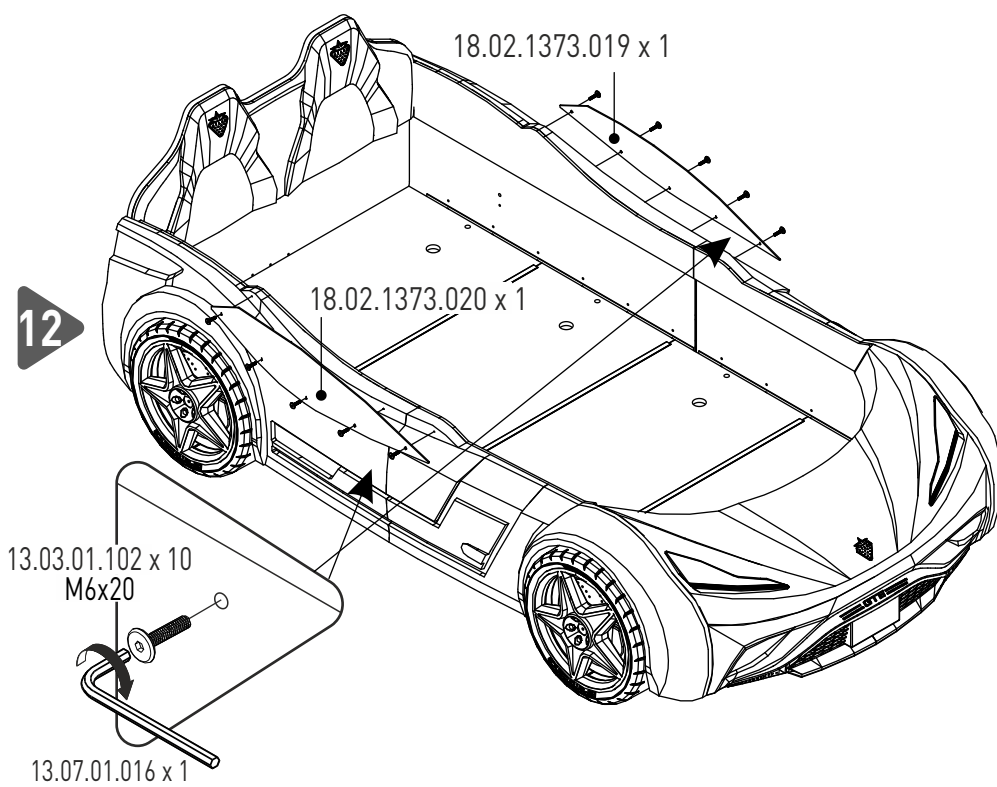

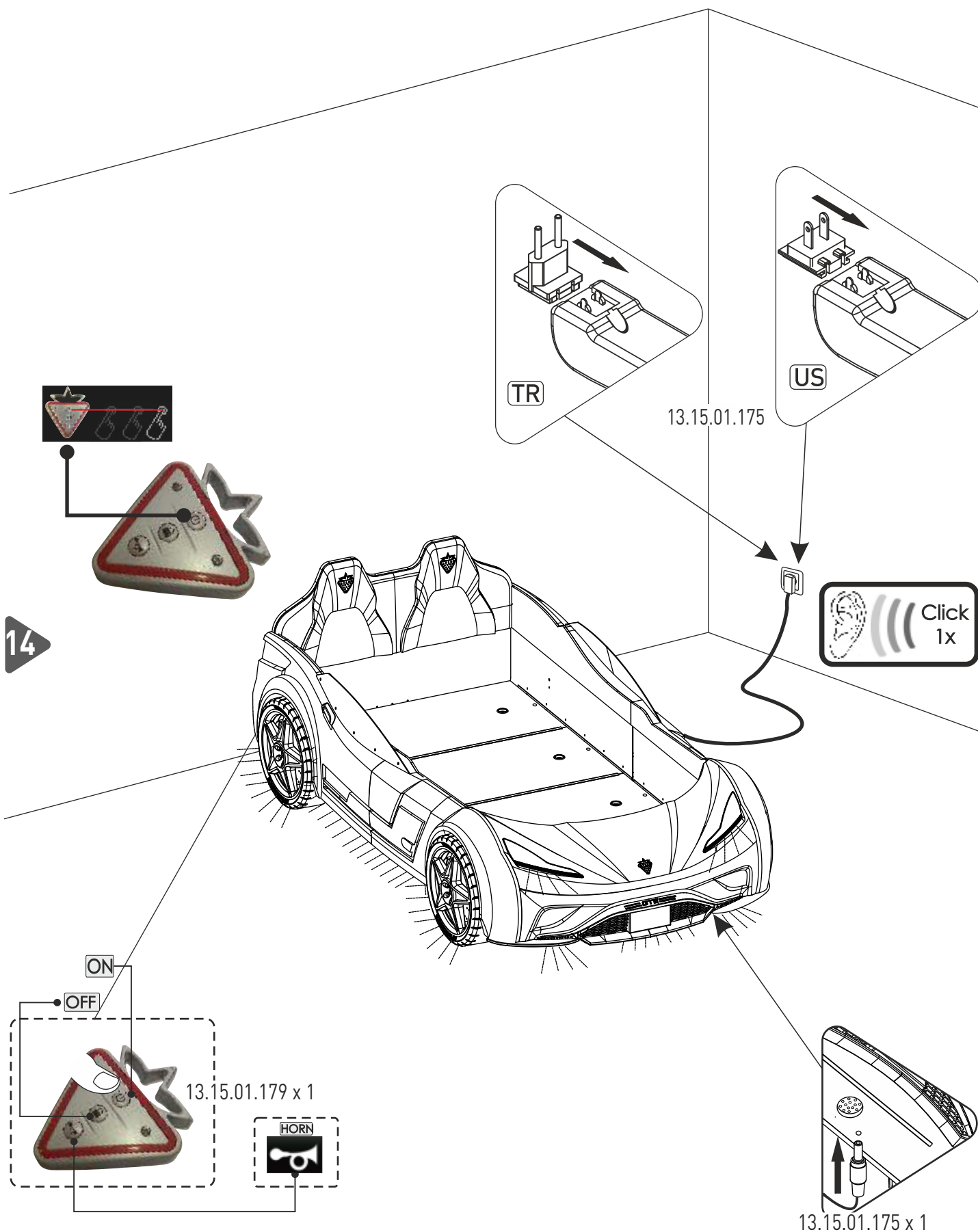

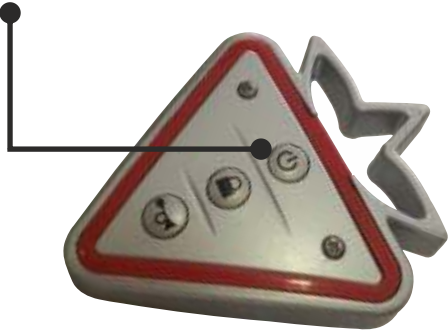

15





13.08.02.117
GTS SOL ÖN YAN H
DAMLALI YAPIŞTIRMA

STICKER YAPIŞTIRMALAR POLİSTREN ÜZERİNDEKİ
STRECH NAYLON KALDIRILDIKTAN SONRA YAPIŞTIRILACAK.
PAKETE KONULURKEN STRECH NAYLON TEKRAR KAPATILACAK



13.08.02.335
GTE SOL ÖN YAN
ÜST KANAL YAPŞ.MAVİ

13.08.02.365
GTE SOL YAN MAVİ
ELECTRIC YAPIŞTIRMA

13.08.02.119
GTS SOL YAN ALT
KANAL YAPIŞTIRMA SİYAH

13.08.02.360
GTE MAVİ SOL ÖN
YAN ETEK YAPIŞ.

13.08.02.108
GTS SOL ÖN YAN
IZGARA SİYAH YAPŞ.

13.08.02.327 GTE MAVİ TAMPON KANAT YAPIŞTIRMA
DELİKLER REFERANS ALINARAK YAPIŞTIRILACAK

1 ADET 13.01.01.714 ÇİLEK LOGO 45 MM KIRMIZI
DELİKLER REFERANS ALINARAK YAPIŞTIRILACAK



1 ADET 13.08.02.375 METALİK GTE YAPIŞTIRMA
KENAR REFERANS ALINARAK YAPIŞTIRILACAK

1 ADET 13.08.02.323 GTE MAVİ DAMLA PLAKA YAPIŞTIRMA
PANJUR ÜZERİNE YAPIŞTIRILACAK

1 ADET 13.08.02.329 GTE TAMPON LEDLİ
SAĞ SIS SİYAH YAPŞ.
TAMPON ÜZERİNE YAPIŞTIRILACAK

1 ADET 13.08.02.328 GTE TAMPON LEDLİ
SOL SIS SİYAH YAPŞ.
TAMPON ÜZERİNE YAPIŞTIRILACAK

STICKER YAPIŞTIRMALAR POLİSTREN ÜZERİNDEKİ
STRECH NAYLON KALDIRILDIKTAN SONRA YAPIŞTIRILACAK.
PAKETE KONULURKEN STRECH NAYLON TEKRAR KAPATILACAK

13.08.02.122
GTS SAĞ ÖN YAN H
DAMLALI YAPIŞTIRMA



13.08.02.337
GTE SAĞ ÖN YAN
ÜST KANAL YAPŞ.MAVİ

13.08.02.366
GTE SAĞ YAN MAVİ
ELECTRIC YAPIŞTIRMA

13.08.02.107
GTS SAĞ ÖN YAN
IZGARA SİYAH YAPŞ.

13.08.02.362
GTE MAVİ SAĞ ÖN
YAN ETEK YAPİŞ.

13.08.02.124
GTS SAĞ YAN ALT
KANAL YAPIŞTIRMA SİYAH



13.08.02.344
GTE MAVİ SAĞ ARKA YAN
KAPI YAPIŞTIRMA

13.08.02.330
GTE ELEKTRİKLİ ŞARJ
DAMLA YAPIŞTIRMA

13.08.02.115
GTS SAĞ ARKA YAN
SİNYAL YAPIŞTIRMA

13.08.02.338
GTE SAĞ ARKA YAN ÜST
KANAL YAPŞ.MAVİ

13.08.02.361
GTE MAVİ SAĞ ARKA
YAN ETEK YAPIŞ.

13.08.02.121
GTS SAĞ SOL ARKA YAN
ALT KANAL YAPIŞ.

STİCKER YAPIŞTIRMALAR POLİSTREN ÜZERİNDEKİ
STRECH NAYLON KALDIRILDIKTAN SONRA YAPIŞTIRILACAK.
PAKETE KONULURKEN STRECH NAYLON TEKRAR KAPATILACAK